

# America West Drilling Supply



## Nova IR360 Shank

### Hammer Specifications

Length (w/o drill bit)	46.52"
Outside Diameter	5.67"
Weight (w/o bit)	236 lbs.
Cylinder Bore	4.74"
Piston O.D.	4.736"
Piston Stroke	
Piston Weight	
Hole Sizes	6 1/16" - 8"
Air Pressure Consumption	150 psi - 350 psi
Wrench Size	A/F 3.968"
Connection (API Reg Pin)	Std. 3 1/2"

### Features:

- *No foot valve required*
- Easy to service
- Special heat-treated alloy piston for long life - Rockwell 60 Hardness
- Minimal performance loss when injecting foam or water

1350 E. Glendale Avenue  
Sparks, NV 89431  
(800) 800-8444 | (775) 355-1199  
Fax (775) 355-8775



[www.awds.com](http://www.awds.com)

# America West Drilling Supply

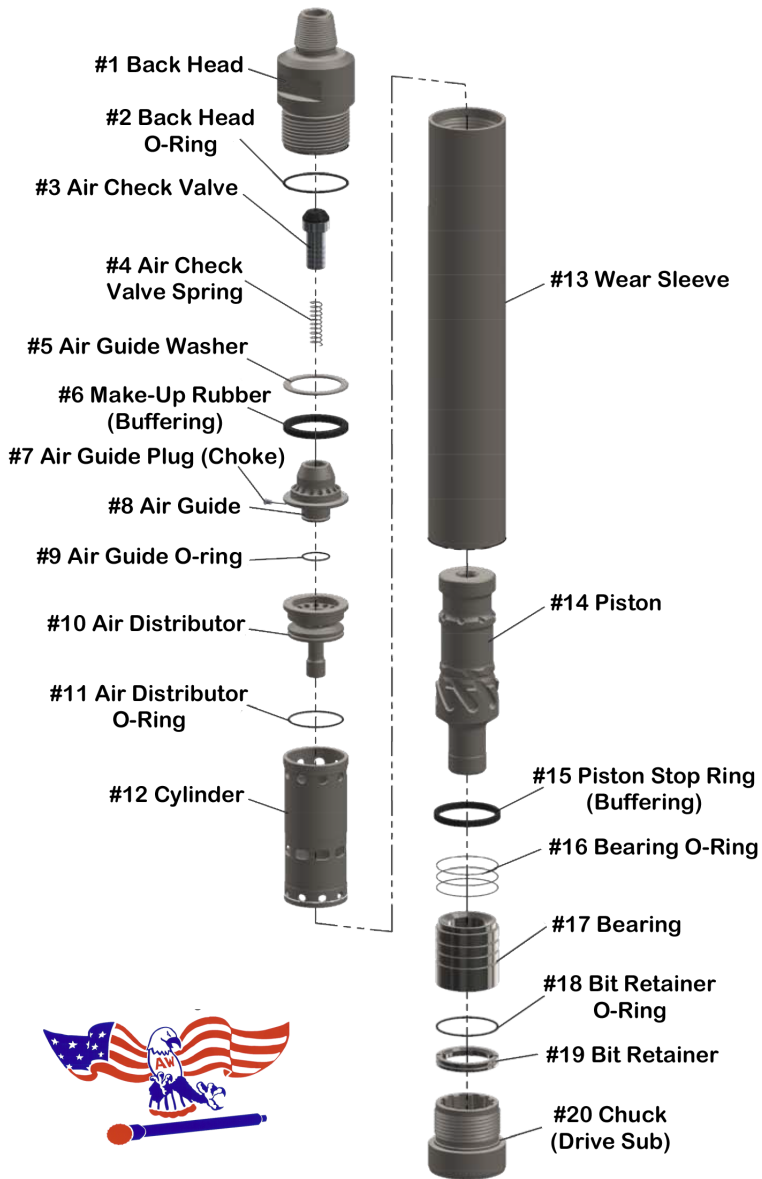

Item #	Description	Part #
1	Back Head	GFN6501
2	Back Head O-Ring	GFN6502
3	Air Check Valve	GFN6503
4	Air Check Valve Spring	GFN6504
5	Air Guide Washer	GFN6505
6	Make-up Rubber	GFN6506
7	Air Guide Plug (Choke)	GFN6507
8	Air Guide	GFN6508
9	Air Guide O-Ring	GFN6509
10	Air Distributor	GFN6510
11	Air Distributor O-Ring	GFN6511
12	Cylinder	GFN6512
13	Wear Sleeve	GFNR6513
14	Piston	GFNR6514
15	Piston Stop Ring (Buffering)	GFN6515
16	Bit Bearing O-Ring	GFN6516
17	Bit Bearing	GFNR6517
18	Bit Retainer O-Ring	GFN6518
19	Bit Retainer	GFNR6519
20	Chuck (Drive Sub)	GFNR6520



## G-Force Nova IR360 Shank Hammer

Air Consumption Chart

PSI	150	200	250	300	350	400
CFM with blank choke	-	552	770	845	970	-
with 1/8" choke	-	579	820	895	1,020	-
with 1/4" choke	-	615	868	966	1,092	-

All hammers come fitted with a blank choke in the Air Check Valve.