

America West Drilling Supply



Nova IR380 Shank

Hammer Specifications

Length (w/o drill bit)	56.1"
Outside Diameter	7.25"
Weight (w/o bit)	441 lbs.
Cylinder Bore	5.925"
Piston O.D.	5.92"
Piston Stroke	4.52"
Piston Weight	92.6 lbs.
Hole Sizes	7 7/8" - 10"
Air Pressure Consumption	150 psi - 350 psi
Wrench Size	A/F 5.512"
Connection (API Reg Pin)	Std. 4 1/2"

Features:

- *No foot valve required*
- Easy to service
- Special heat-treated alloy piston for long life - Rockwell 60 Hardness
- Minimal performance loss when injecting foam or water

1350 E. Glendale Avenue
Sparks, NV 89431
(800) 800-8444 | (775) 355-1199
Fax (775) 355-8775



www.awds.com

America West Drilling Supply

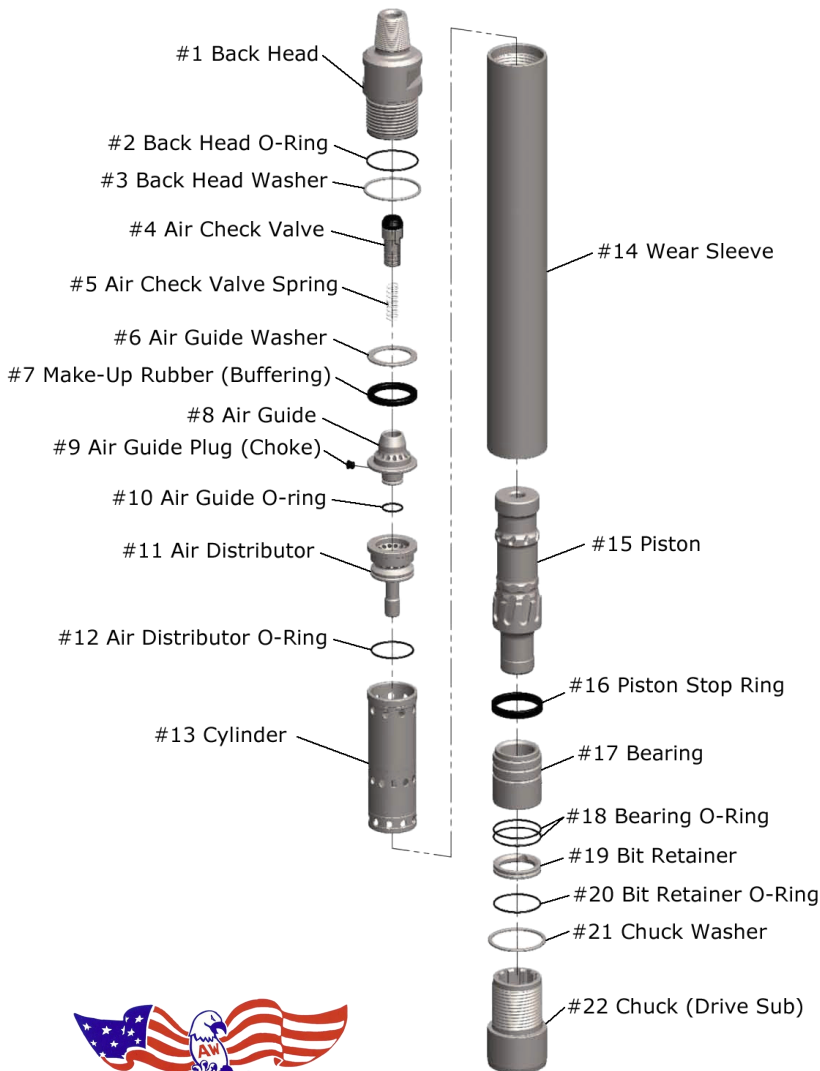

Item #	Description	Part #
1	Back Head	GFN8501
2	Back Head O-Ring	GFN8502
3	Back Head Washer	GFN8503
4	Air Check Valve	GFN8504
5	Air Check Valve Spring	GFN8505
6	Air Guide Washer	GFN8506
7	Make-up Rubber	GFN8507
8	Air Guide	GFN8508
9	Air Guide Plug (Choke)	GFN8509
10	Air Guide O-ring	GFN8510
11	Air Distributor	GFN8511
12	Air Distributor O-ring	GFN8512
13	Cylinder	GFN8513
14	Wear Sleeve	GFNR8514
15	Piston	GFNR8515
16	Piston Stop Ring (Buffering)	GFN8516
17	Bit Bearing	GFNR8517
18	Bit Bearing O-Ring	GFN8518
19	Bit Retainer	GFNR8519
20	Bit Retainer O-Ring	GFN8520
21	Chuck Washer	GFN8521
22	Chuck (Drive Sub)	GFNR8522



G-Force Nova IR380 Shank Hammer

Air Consumption Chart

PSI	150	200	250	300	350	400
CFM with blank choke	445	650	850	1,045	1,240	-
with 1/8" choke	-	-	-	-	-	-
with 1/4" choke	-	-	-	-	-	-

All hammers come fitted with a blank choke in the Air Check Valve.