

VS-220 HD PRO™



CME's redesigned high powered handheld grinder brings health and safety, ergonomics, operator comfort and serviceability to new levels. The VS-220 HD PRO uses the same internal motor as the VS-220 HD for complete backwards compatibility. An integrated grinding cup puller with brake and splash guards keeps the operator dry and safe while simplifying installation and removal of a grinding cup.



TECHNICAL DATA

Spindle Speed	22 000 rpm
Motor	Air powered
Power Output	1.8 KW (2.4 Hp)
Working Air Pressure	7-8 bar (100-115 psi)
Air Consumption	2.2 m ³ /min (78 ft ³ /min)
Air Hose Diameter	19 mm (0.75")
Water Hose Diameter	6 mm (0.25")
Water/Coolant Pressure	4 bar (60 psi), max
Weight excl. Packaging	3.9 kg (8.6 lbs)
Weight incl. Packaging	5.0 kg (11.0 lbs)
Transport Dimensions	500 x 250 x 260mm 20" x 10" x 10.25"
Sound Level	115 dB(A), 82 dB(A) with silencer
Vibration Level	< 2.5 m/s ²
Incl. accessories	-Splash guards with puller/brake -Button bit gauge
Optional accessories	-Service tool kit -Filter, regulator, lubricator with hoses and fittings kit

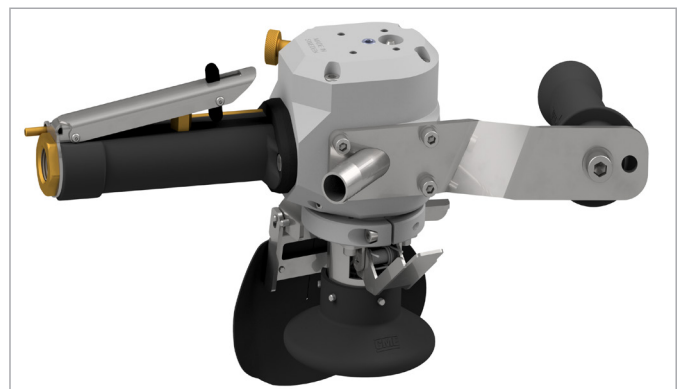

Note: Must be completed with CME's patented Super Diaroc HD grinding cups.



Manufacturer of Button Bit
Grinding Equipment for
Over 40 Years

International Head Office
CME Blasting and Mining Equipment Limited
333 Wyecroft Road - Unit #9
Oakville, Ontario, L6K 2H2, Canada
Phone: +1(905)849-4530,
Fax: +1(905)849-4532
Web: www.cmemining.com

European Branch - CME AB
Construction Mining Equipment AB
Backa Bergögata 7, 422 46
Hisings Backa, Sweden
Phone: +46(031)54 10 96,
Fax: +46(031)53 28 50
Web: www.cme.se

Brazil Branch - CME do Brazil
Rua Lagoa Dourada , 460 - Prado
Belo Horizonte, Brazil
Tel: +55 (031) 2555-3489
Fax: +55 (031) 2555-3489
Web: www.cmemining.com