

America West Drilling Supply



Nova IR350 Shank

Hammer Specifications

Length (w/o drill bit)	39.8"
Outside Diameter	4.88"
Weight (w/o bit)	146.4 lbs.
Cylinder Bore	3.547"
Piston O.D.	3.54"
Piston Stroke	2.09"
Piston Weight	32.5 lbs.
Hole Sizes	5 1/8" - 6"
Air Pressure Consumption	150 psi - 450 psi
Wrench Size	A/F 3.47"
Connection (API Reg Pin)	Std. 3 1/2"

Features:

- *No foot valve required*
- Easy to service
- Special heat-treated alloy piston for long life - Rockwell 60 Hardness
- Minimal performance loss when injecting foam or water

1350 E. Glendale Avenue
Sparks, NV 89431
(800) 800-8444 | (775) 355-1199
Fax (775) 355-8775



www.awds.com

America West Drilling Supply

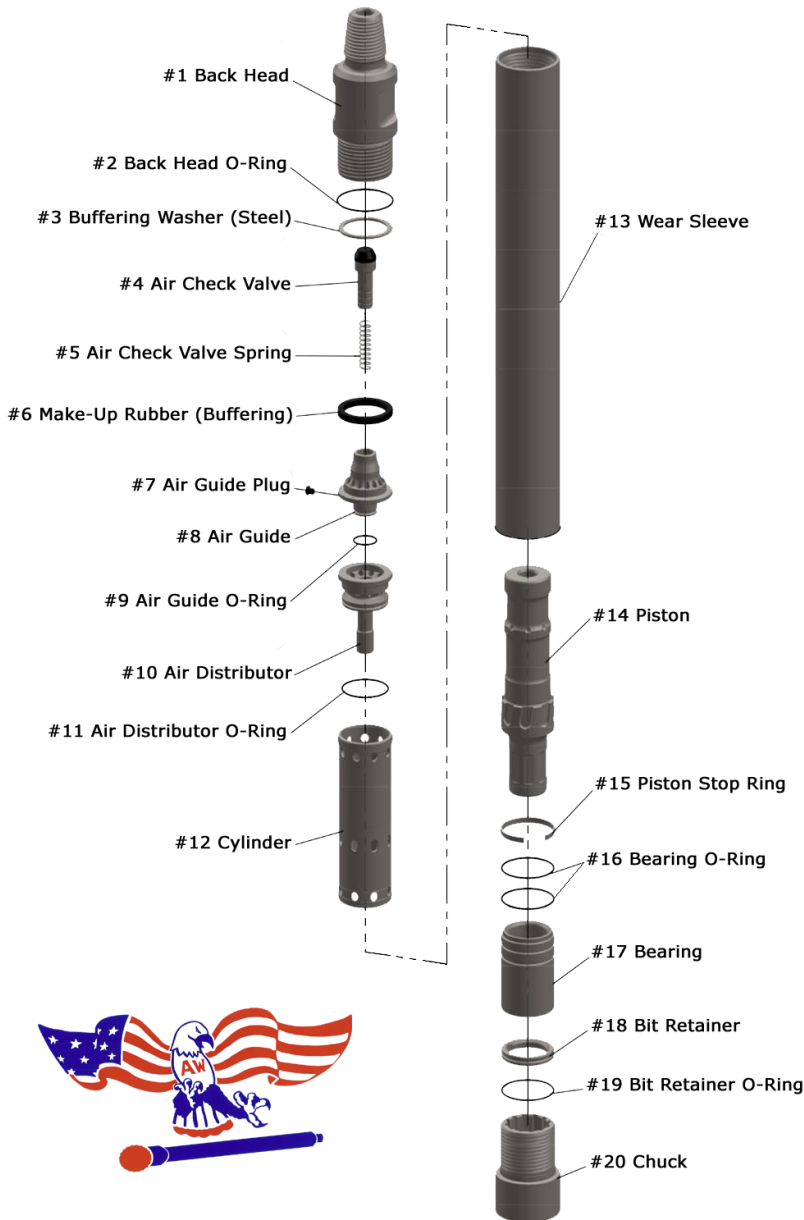

Item #	Description	Part #
1	Back Head	GFN5501
2	Back Head O-Ring	GFN5502
3	Air Check Valve	GFN5503
4	Air Check Valve Spring	GFN5504
5	Air Guide Washer	GFN5505
6	Make-up Rubber	GFN5506
7	Air Guide Plug (Choke)	GFN5507
8	Air Guide	GFN5508
9	Air Guide O-Ring	GFN5509
10	Air Distributor	GFN5510
11	Air Distributor O-Ring	GFN5511
12	Cylinder	GFN5512
13	Wear Sleeve	GFNR5513
14	Piston	GFNR5514
15	Piston Stop Ring (Buffering)	GFN5515
16	Bit Bearing O-Ring	GFN5516
17	Bit Bearing	GFNR6517
18	Bit Retainer O-Ring	GFN6518
19	Bit Retainer	GFNR5519
20	Chuck (Drive Sub)	GFNR5520



G-Force Nova IR350 Shank Hammer

Air Consumption Chart

PSI	150	200	250	300	350	400
CFM with blank choke	343	481	618	748	893	1,031
with 1/8" choke	388	528	668	808	948	1,088
with 1/4" choke	423	578	733	888	1,043	1,198

All hammers come fitted with a blank choke in the Air Check Valve.