

America West Drilling Supply



G-Force QL40 Shank

Hammer Specifications

Length (w/o drill bit)	40.55"
Outside Diameter	3.858"
Weight (w/o bit)	82.9 lbs.
Cylinder Bore	3.229"
Piston O.D.	3.224"
Piston Stroke	3.74"
Piston Weight	20.3 lbs.
Hole Sizes	4" - 6"
Air Pressure Consumption	100 psi - 350 psi
Wrench Size	A/F 3.15"
Connection (API Reg Pin)	Std. 2 7/8"

Features:

- Easy to service
- Special heat-treated alloy piston for long life - Rockwell 60 Hardness
- Minimal performance loss when injecting foam or water

1350 E. Glendale Avenue
Sparks, NV 89431
(800) 800-8444 | (775) 355-1199
Fax (775) 355-8775



www.awds.com

America West Drilling Supply

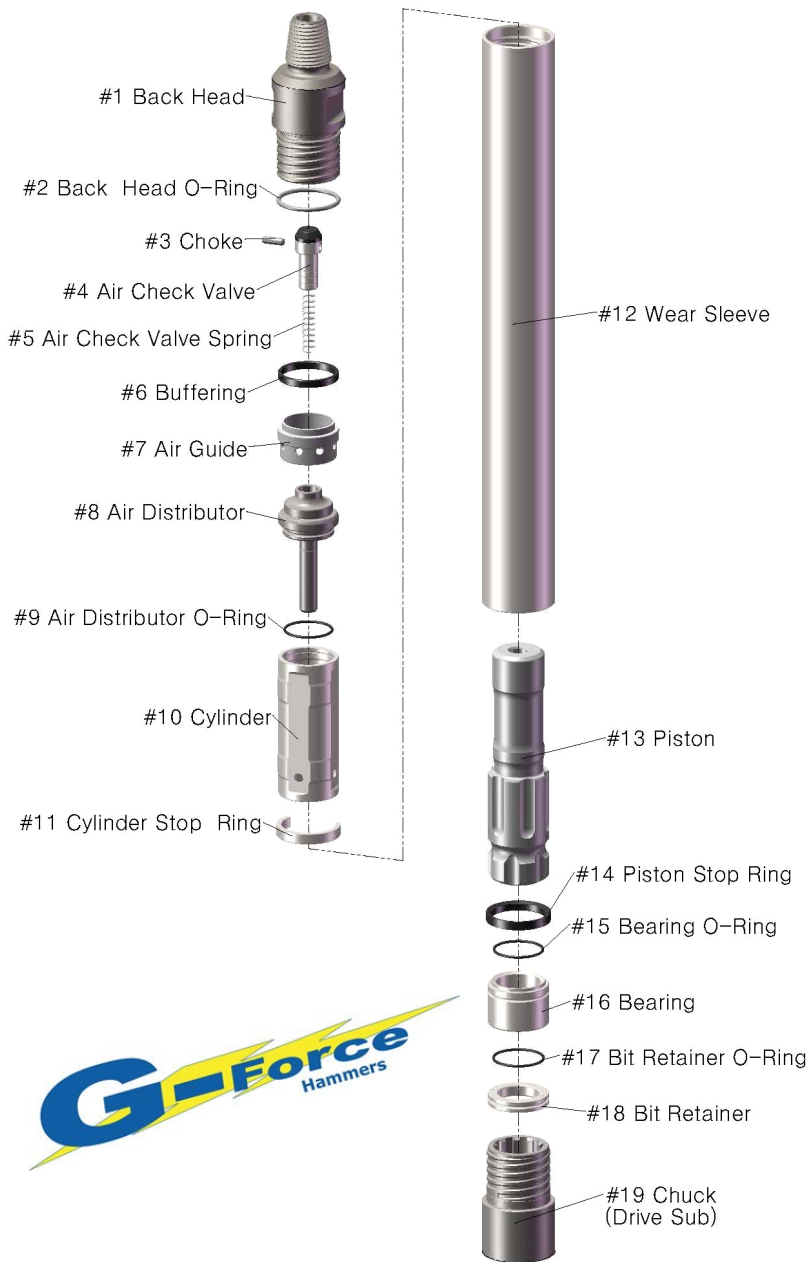

Item #	Description	Part #
1	Back Head	G4001
2	Back Head O-Ring	G4002
3	Choke	
4	Air Check Valve	G4004
5	Air Check Valve Spring	G4005
6	Make-Up Rubber (Buffering)	G4006
7	Air Guide	G4007
8	Air Distributor	G4008
9	Air Distributor O-Ring	G4009
10	Cylinder	G4010
11	Cylinder Stop Ring	G4011
12	Wear Sleeve	G4QL4012
13	Piston	G4QL4013
14	Piston Stop Ring	G4QL4014
15	Bit Bearing O-Ring	G4QL4015
16	Bit Bearing	G4QL4016
17	Bit Retaining O-Ring	G4QL4017
18	Bit Retaining Ring	G4QL4018
19	Chuck (Drive Sub)	G4QL4019
	Choke Plug Kit	G4029
	O-Ring Kit	G4030

G-Force QL40 Shank Hammer

Air Consumption Chart						
PSI	150	200	250	300	350	400
CFM with blank choke	240	340	440	540	-	-
with 1/8" choke	375	595	760	925	1,060	1,205
with 1/4" choke	425	665	845	1,095	1,270	1,350

All hammers come fitted with a blank choke in the Air Check Valve.