

America West Drilling Supply



LXQ IR3.5 Shank

Hammer Specifications

Length (w/o drill bit)	38.07"
Outside Diameter	3.14"
Weight (w/o bit)	48.4 lbs.
Cylinder Bore	2.559"
Piston O.D.	2.555"
Piston Stroke	3.54"
Piston Weight	9.7 lbs.
Hole Sizes	3 3/8" - 5"
Air Pressure Consumption	100 psi - 350 psi
Wrench Size	A/F 2.559"
Connection (API Reg Pin)	Std. 2 3/8"

Features:

- Easy to service
- Special heat-treated alloy piston for long life - Rockwell 60 Hardness
- Minimal performance loss when injecting foam or water
- Drills well underwater

1350 E. Glendale Avenue
Sparks, NV 89431
(800) 800-8444 | (775) 355-1199
Fax (775) 355-8775



www.awds.com

America West Drilling Supply

Missile LXQ Series

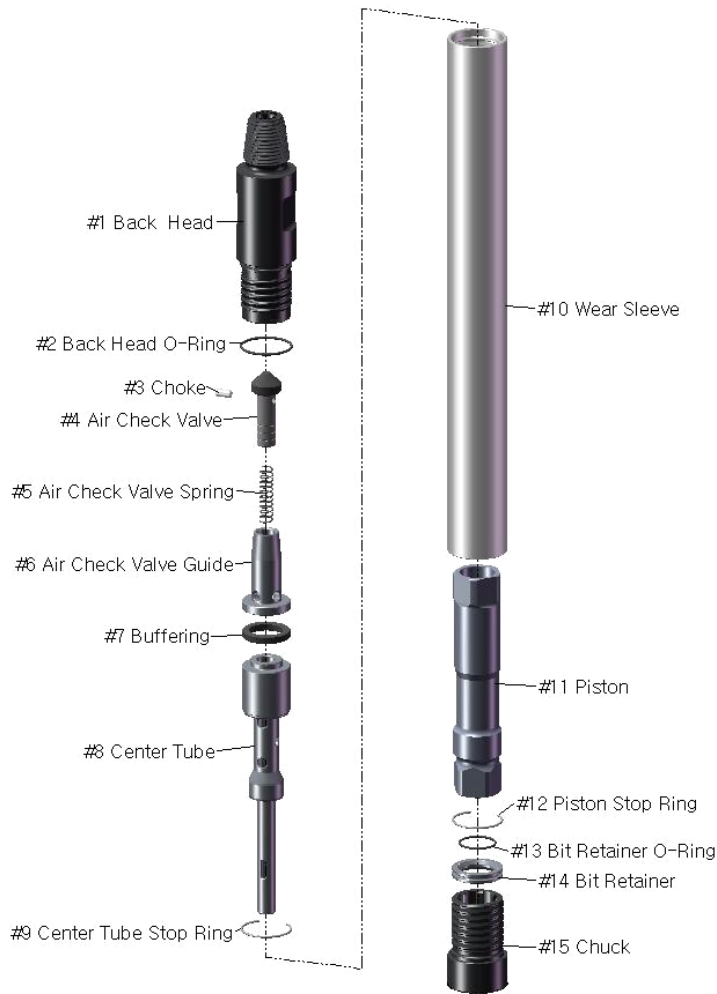

Item #	Description	Part #
1	Back Head	LQ3001
2	Back Head O-Ring	LQ3002
3	Choke	
4	Air Check Valve	LQ3004
5	Air Check Valve Spring	LQ3005
6	Air Check Valve Guide	LQ3006
7	Make-Up Rubber (Buffering)	LQ3007
8	Center Tube	LQ3008
9	Center Tube Stop Ring	LQ3009
10	Wear Sleeve	LQ3010
11	Piston	LQ3011
12	Piston Stop Ring	LQ3012
13	Bit Retaining O-Ring	LQ3013
14	Bit Retaining Ring	LQ3014
15	Chuck (Drive Sub)	LQ3015
	Choke Plug Kit	LQ3029
	O-Ring Kit	LQ3030



LXQ IR3.5 Shank Hammer

Air Consumption Chart

PSI	100	150	200	250	300	350	400
CFM with blank choke	110	180	250	330	415	505	605
with 1/8" choke	-	-	-	-	-	-	-
with 1/4" choke	-	-	-	-	-	-	-

All hammers come fitted with a blank choke in the Air Check Valve.