

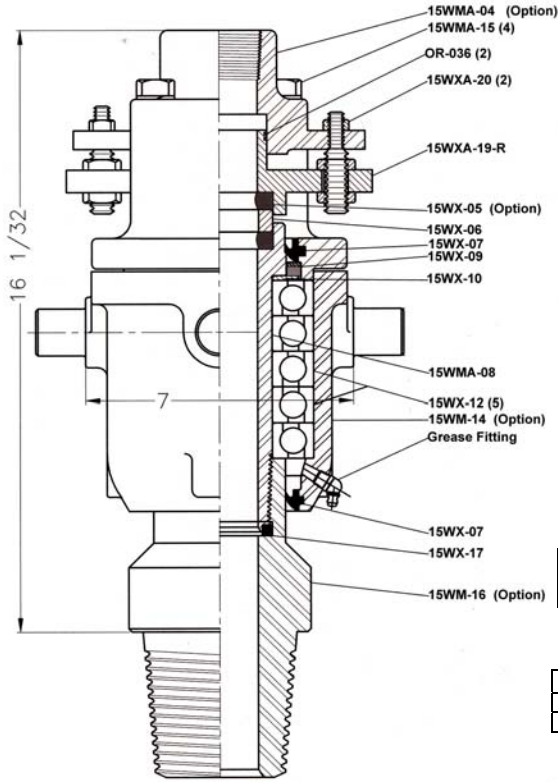

15WMA



- For Drilling Rigs with Chain or Cable PULL DOWN
- Constructed from alloy steel for durability
- For MUD and AIR drilling
- Can be furnished with bail
- Trunnion Pins to 1-3/4"
- Thrust ball bearing for supporting pipe load and radial load
- Designed for easy service and field maintenance
- Choice of Lower Connection Threads.
- 15WMA FEATURES ADJUSTABLE PACKING

TECHNICAL DATA

PACKING	LENGTH OVERALL	WT/LBS EACH	HOSE CONN. FEMALE	LOWER CONN.	WATER PRESSURE	WORKING OPENING
ADJUSTABLE	24 1/2"	105	2" NPT	2 7/8" IF LH	2"	To 300 PSI

SAFE WEIGHT LOADS

STATIC LOAD	ROTATING LOAD	DRILL DEPTH	SIZE/WT/FT
30,000 LBS.	27,000 LBS. @ 100 RPM	2,700 FT	2 3/8" / 6.65 LBS
		1,800 FT	2 7/8" / 10.4 LBS

PARTS LIST

PART NO.	DESCRIPTION	WT/LBS	QTY. REQ.	
15WMA-3700-XX	WESTERN SWIVEL, LESS BAIL, 2" NPT FEMALE HOSE CONNECTION, WITH ADJUSTMENT PACKING, FOUR (4) PULLDOWN TRUNNION PINS, WITH 2 7/8" IF LEFT HAND PIN LOWER CONNECTION			
	ADD FOR BAIL			
	ADD FOR SPECIAL LOWER CONNECTION			
15WM-01	BAIL	25.00	OPTION	
15WMA-04	GOOSENECK	39.00	OPTION	
15WX-05	+PACKING	.12	2	
15WX-05-90	PACKING, 90 DURO	.12	OPTION	
15WX-06	+WEARBUSHING	.75	1	
15WX-07	+HOUSING SEAL	.25	2	
15WMA-08	SPINDLE	10.00	1	
15WX-09	+SHIELD SEAL	.20	1	
15WX-10	+BEARING SHIELD	.25	1	
15WX-12	+BEARINGS	5.00	5	
15WM-14A	BEARING HOUSING, 7" SHOULDERS, (4) 1 3/4" PINS	24.00	OPTION	
15WMA-15	STUDS W/NUT	.75	4	
15WM-16GD-LP	LOWER CONNECTION, 2 7/8" OD 8-V LH PIN	12.00	OPTION	
15WM-16GE-LP	LOWER CONNECTION, 2 7/8" IF LH PIN	12.00	1	
15WM-16FE-LP	LOWER CONNECTION, 2 3/8" IF LH PIN	12.00	OPTION	
15WX-17	+SPINDLE THREAD SEAL	.06	1	
15WXA-19-R	GLAND, PACKING ADJUSTING	8.25	1	
15WXA-20	ADJUST SCREW W/NUTS	1.25	2	
OR-036	+O RING	.01	2	
15WX-40	MAINTENANCE KIT (8) 15WX-05, (1) 15WX-06			
15WMA-40R	REPAIR KIT +INCLUDED IN REPAIR KIT			

Other sizes of connections available, please consult factory.

Option for above swivel, may affect pricing of complete swivel. Other options available, please consult factory.

