

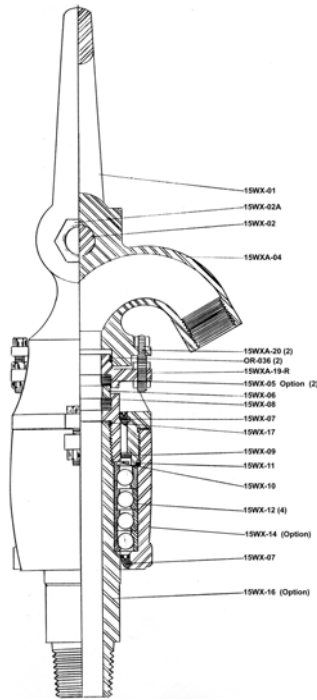

15 WXA

Adjustable Packing Swivel



- For WATER, GEOPHYSICAL, and MONITORING well drilling
- Light Weight
- Alloy Steel construction for strength
- Large Watercourse
- For Pulldown or Kelly Bar machines
- Flexible BAIL or ELEVATOR SHANK available
- Thrust ball bearings support drill pipe load while providing radial capacity.
- Seal Bearing Case with grease lubrication
- TRUNNION PINS available
- Choice of lower connection threads
- Designed for easy field service and maintenance

TECHNICAL DATA

LENGTH OVERALL	WT/LBS EACH	HOSE CONN. FEMALE	LOWER CONN* PIN	WATER COURSE	WORKING OPENING	BAIL OPENING
36"	125	2" NPT	2-7/8" OD 8-V LH	MAX 2" ID	To 300 PSI	3-3/4" X 8"

SAFE WEIGHT LOADS

STATIC LOAD	ROTATING LOAD	SAFE DEPTH			
		2-3/8", 6.65	2-7/8", 10.4	3-1/2", 13.3	4-1/2", 16.6
50,000 LBS.	27,000 LBS. @ 100 RPM	2,700 FT	1,800 FT	----	----

PARTS LIST

PART NUMBER	DESCRIPTION	WT/LB EACH	QTY. REQ.	
15WXA-3010-XX	WESTERN SWIVEL, LESS BAIL, 2" NPT FEMALE HOSE CONNECTION, WITH ADJUSTABLE PACKING, WITH 2 7/8" OD 8-V LH PIN LOWER CONNECTION			
	ADD FOR BAIL			
	ADD FOR "SPECIAL SPINDLE"			
	ADD FOR TRUNNION PINS			
15WX-01	BAIL	16.00	OPTION	
15WX-01E	ELEVATOR SHANK	38.00	OPTION	
15WX-02	BAIL PIN	3.50	1	
15WX-02A	BAIL PIN NUT	.50	2	
15WXA-04A	GOOSENECK, 2" NPT FEMALE	43.00	1	
15WX-05	+ PACKING	.25	2	
15WX-05-90	PACKING, 90 DURO (RED)	.25	OPTION	
15WX-05V	PACKING, VITON	.25	OPTION	
15WX-06	+ WEARBUSHING	.50	1	
15WX-07	+ HOUSING SEAL	.12	2	
15WX-07V	HOUSING SEAL, VITON	.12	OPTION	
15WX-08	SPINDLE NUT	3.50	1	
15WX-09	+ SHIELD SEAL	.25	1	
15WX-10	+ BEARING SHIELD	.37	1	
15WX-11	BEARING RETAINER WIRE	.12	1	
15WX-12	+ BEARINGS	2.75	4	
15WX-14	BEARING HOUSING	16.00	1	
15WX-14A	BEARING HOUSING, 2" OD PINS	28.00	OPTION	
15WX-15	LOCK SCREW AND NUT, BEARING HOUSING	.25	1	
15WX-16GD-LP	SPINDLE, 2 7/8" OD 8V LH PIN	15.00	1	
15WX-16GE-LP	SPINDLE, 2 7/8" IF LH PIN	23.00	OPTION	
15WX-17	+ SPINDLE THREAD SEAL	.06	1	
15WXA-19-R	PACKING ADJUSTING GLAND	8.25	1	
15WXA-20	ADJUSTING SCREW W/NUTS	1.00	2	
OR-036	+ O-RING, ADJUSTING GLAND	.01	2	
15WX-40	MAINTENANCE KIT (8) 15WX-05, (1) 15WX-06			
15WXA-40R	REPAIR KIT, + INCLUDED IN REPAIR KIT			

Other sizes of connections available, please consult factory.

Option for above swivel, may affect pricing of complete swivel. Other options available, please consult factory.

