

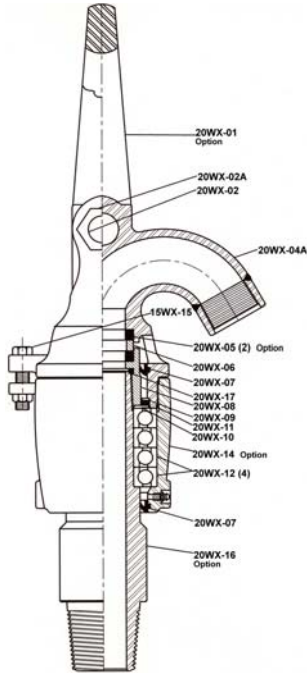

20 WX



- For WATER, GEOPHYSICAL, and MONITORING well drilling
- Light Weight
- Alloy Steel construction for strength
- Large Watercourse
- For Pulldown or Kelly Bar machines
- Flexible BAIL or ELEVATOR SHANK available
- Thrust ball bearings support drill pipe load while providing radial capacity.
- Seal Bearing Case with grease lubrication
- TRUNNION PINS available
- Choice of lower connection threads
- Designed for easy field service and maintenance

TECHNICAL DATA

MODEL #	LENGTH	WT/LBS EACH	HOSE CONN. FEMALE	LOWER CONN* PIN	WATER COURSE	WORKING PRESSURE	BAIL OPENING
20WX	34"	140	2 1/2" NPT	3 1/2" OD 8-V LH	2 1/2" ID	To 300 PSI	4 1/2" X 8"

SAFE WEIGHT LOADS

MODEL #	STATIC LOAD	ROTATING LOAD	SAFE DEPTH			
			2-3/8", 6.65	2-7/8", 10.4	3-1/2", 13.3	4-1/2", 16.6
20WX	70,000 LBS.	36,000 LBS. @ 100 RPM	3,600 FT	2,400 FT	1,800 FT	----

PARTS LIST

PART NO.	DESCRIPTION	WT/LBS	QTY. REQ.	
20WX-3020-XX	WESTERN SWIVEL, LESS BAIL, 2 1/2" NPT FEMALE HOSE CONNECTION WITH 3 1/2" OD 8V LH PIN / 3 1/2" IF LH PIN LOWER CONNECTION			
	ADD FOR BAIL			
	ADD FOR PULLDOWN TRUNNION PINS			
	ADD FOR SPECIAL LH PIN LOWER CONNECTION			
20WX-01	BAIL	21.00	1	
20WX-02	BAIL PIN	4.00	1	
20WX-02A	BAIL PIN NUT	.75	2	
20WX-04A	GOOSENECK, 2 1/2" NPT FEMALE HOSE CONNECTION	43.00	1	
20WX-05	+ PACKING	.25	2	
20WX-05-90	PACKING, 90 DURO HIGH PRESSURE	.25	Option	
20WX-05V	PACKING, VITON	.25	Option	
20WX-06	+ WEARBUSHING	1.00	1	
20WX-07	+ HOUSING SEALS	.12	2	
20WX-07V	HOUSING SEALS, VITON	.12	Option	
20WX-08	SPINDLE NUT	4.50	1	
20WX-09	+ SHIELD SEAL	.37	1	
20WX-10	+ BEARING SHIELD	.50	1	
20WX-11	BEARING RETAINER WIRE	.12	1	
20WX-12	+ BEARINGS	4.25	4	
20WX-14	BEARING HOUSING	28.00	1	
20WIR-14A	BEARING HOUSING, 7 1/2" SHOULDERS / 2" TRUNNION PINS	37.00	Option	
20WIR-14B	BEARING HOUSING, 8 5/16" SHOULDERS / 2" TRUNNION PINS	37.00	Option	
15WX-15	LOCK SCREW AND NUT, BEARING HOUSING	.25	1	
20WX-16JD-LP	LOWER CONNECTION, 3 1/2" OD 8-V LH PIN	28.00	1	
20WX-16JE-LP	LOWER CONNECTION, 3 1/2" IF LH PIN	34.00	Option	
20WX-16GE-LP	LOWER CONNECTION, 2 7/8" IF LH PIN	33.00	Option	
20WX-17	+ SPINDLE THREAD SEAL	.06	1	
20WX-40	MAINTENANCE KIT (8) 20WX-05, (1) 20WX-06			
20WX-40R	REPAIR KIT + Included in Repair Kit			

Other sizes of connections available, please consult factory.

Option for above swivel, may affect pricing of complete swivel. Other options available, please consult factory.

